

METRIC

MIL-PRF-17331J

09 September 2003

SUPERSEDING

MIL-PRF-17331H(SH)

23 January 1984

PERFORMANCE SPECIFICATION

LUBRICATING OIL, STEAM TURBINE AND GEAR, MODERATE SERVICE

This specification is approved for use by all Departments and Agencies of the Department of Defense.

1. SCOPE

1.1 Scope. This specification covers a single classification of steam turbine and gear lubricating oil, moderate service, for use in main and auxiliary turbines and gears, air compressors, and certain hydraulic equipment, as well as for general mechanical lubrication. The lubricating oil will be identified as follows:

Military symbol

2190 TEP

NATO symbol

O-250

2. APPLICABLE DOCUMENTS

2.1 General. The documents listed in this section are specified in sections 3 and 4 of this specification. This section does not include documents cited in other sections of this specification or recommended for additional information or as examples. While every effort has been made to ensure the completeness of this list, document users are cautioned that they must meet all specified requirements documents cited in sections 3 and 4 of this specification, whether or not they are listed.

Comments, suggestions, or questions on this document should be addressed to Commander, Naval Sea Systems Command, ATTN: SEA 05Q, 1333 Isaac Hull Avenue, SE, Stop 5160, Washington Navy Yard DC 20376-5160 or emailed to commandstandards@navsea.navy.mil, with the subject line "Document Comment". Since contact information can change, you may want to verify the currency of this address information using the ASSIST Online database at www.dodssp.daps.mil.

2.2 Government documents.

2.2.1 Specifications, standards, and handbooks. The following specifications, standards, and handbooks form a part of this document to the extent specified herein. Unless otherwise specified, the issues of these documents are those listed in the issue of the Department of Defense Index of Specifications and Standards (DoDISS) and supplement thereto, cited in the solicitation (see 6.2).

STANDARDS

FEDERAL

FED-STD-791 - Lubricants, Liquid Fuels, and Related Products; Methods of Testing

(Unless otherwise indicated, copies of the above specifications, standards, and handbooks are available from the Standardization Document Order Desk, 700 Robbins Avenue, Building 4/D, Philadelphia, PA 19111-5094 or <http://astimage.daps.dla.mil/quicksearch/> or [www.dodssp.daps.mil.](http://www.dodssp.daps.mil/))

2.2.2 Other Government Documents.

BUMED INST 6270.8 - Procedures for Obtaining Health Hazard Assessments Pertaining to Operational Use of Hazardous Material.

(Unless otherwise indicated, copies of the above document are available from Bureau of Medicine and Surgery, Department of the Navy, 2300 E Street, NW, Washington, DC 20372-5300 or [https://bumed.med.navy.mil.](https://bumed.med.navy.mil/))

S9510-AB-ATM-010/(U) - Nuclear-Powered Submarine Atmosphere Control Manual, Chapter 7

(Unless otherwise indicated, copies of the above document are available from Commander Naval Sea Systems Command, ATTN: SEA 05Z9, 1333 Isaac Hull Ave., SE, Stop 5133, Washington Navy Yard DC 20376-5133 or [https://smcl.dt.navy.mil./](https://smcl.dt.navy.mil/))

2.3 Non-Government publications. The following documents form a part of this document to the extent specified herein. Unless otherwise specified, the issues of the documents which are DoD adopted are those listed in the issue of the DoDISS cited in the solicitation. Unless otherwise specified, the issues of documents not listed in the DoDISS are the issues of the documents cited in the solicitation. (See 6.2.)

AMERICAN NATIONAL STANDARDS INSTITUTE (ANSI)

ANSI/ASQC Z1.4 - Sampling Procedures and Tables for Inspection by Attributes. (DoD adopted)

(Application for copies should be addressed to the American National Standards Institute, Inc., 11 West 42nd Street, 13th Floor, New York, NY 10036 or [www.ansi.org.](http://www.ansi.org))

ASTM INTERNATIONAL

D92 - Flash and Fire Points by Cleveland Open Cup Tester. (DoD adopted)
D95 - Water in Petroleum Products and Bituminous Materials by Distillation. (DoD adopted)

- D97 - Pour Point of Petroleum Products. (DoD adopted)
- D129 - Sulfur in Petroleum Products (General Bomb Method). (DoD adopted)
- D130 - Detection of Copper Corrosion from Petroleum Products by the Copper Strip Tarnish Test. (DoD adopted)
- D287 - API Gravity of Crude Petroleum and Petroleum Products (Hydrometer Method). (DoD adopted)
- D445 - Kinematic Viscosity of Transparent and Opaque Liquids (the Calculation of Dynamic Viscosity). (DoD adopted)
- D665 - Rust-Preventing Characteristics of Inhibited Mineral Oil in the Presence of Water. (DoD adopted)
- D892 - Foaming Characteristics of Lubricating Oils. (DoD adopted)
- D943 - Oxidation Characteristics of Inhibited Mineral Oils. (DOD adopted)
- D974 - Acid and Base Number by Color-Indicator Titration. (DoD adopted)
- D1298 - Density, Relative Density (Specific Gravity), or API Gravity of Crude Petroleum and Liquid Petroleum Products by Hydrometer Method. (DoD adopted)
- D1401 - Water Separability of Petroleum Oils and Synthetic Fluids. (DOD adopted).
- D1552 - Sulfur in Petroleum Products (High-Temperature Method). (DoD adopted)
- D2272 - Oxidation Stability of Steam Turbine Oils by Rotating Pressure Vessel. (DOD adopted)
- D2622 - Sulfur in Petroleum Products by Wavelength Dispersive X-Ray Fluorescence Spectrometry. (DoD adopted)
- D2783 - Measurement of Extreme-Pressure Properties of Lubricating Fluids (Four-Ball Method).
- D3427 - Air Release Properties of Petroleum Oils.
- D4052 - Density and Relative Density of Liquids by Digital Density Meter. (DOD adopted)
- D4057 - Manual Sampling of Petroleum and Petroleum Products, (DOD adopted)
- D4310 - Sludging and Corrosion Tendencies of Inhibited Mineral Oils.
- D4898 - Insoluble Contamination of Hydraulic Fluids by Gravimetric Analysis. (DOD adopted)
- D4927 - Standard Test Methods for Elemental Analysis of Lubricant and Additive Components—Barium, Calcium, Phosphorus, Sulfur, and Zinc by Wavelength-Dispersive X-Ray Fluorescence Spectroscopy. (DOD adopted)
- D5182 - Evaluating the Scuffing Load Capacity of Oils (FZG Visual Method).
- D5950 - Pour Point of Petroleum Products (Automatic Tilt Method).
- D6443 - Standard Test Method for Determination of Calcium, Chlorine, Copper, Magnesium, Phosphorus, Sulfur, and Zinc in Unused Lubricating Oils and Additives by Wavelength Dispersive X-ray Fluorescence Spectrometry (Mathematical Correction Procedure).
- D6481 - Standard Test Method for Determination of Phosphorus, Sulfur, Calcium, and Zinc in Lubrication Oils by Energy Dispersive X-ray Fluorescence Spectroscopy.
- E29 - Using Significant Digits in Test Data to Determine Conformance with Specifications. (DOD adopted)

(Application for copies should be addressed to ASTM International, 100 Barr Harbor Drive, West Conshohocken, PA 19428 or www.astm.org.)

2.4 Order of precedence. In the event of a conflict between the text of this document and the references cited herein (except for related associated detail specifications, specifications, specification sheets or MS standards), the text of this document takes precedence. Nothing in this document, however, supersedes applicable laws and regulations unless a specific exemption has been obtained.

3. REQUIREMENTS

3.1 General. For purposes of determining conformance with each requirement, an observed value or calculated value shall be rounded off to the nearest unit in the last right-hand place of figures used in expressing the limiting value, in accordance with the rounding-off procedure given in ASTM E29.

3.2 Qualification. The lubricating oil furnished under this specification shall be products authorized by the qualifying activity for listing on the applicable Qualified Products List (QPL) before contract award (See 4.2 and 6.3).

3.2.1 Re-qualification. Products shall be re-qualified every 5 years. In addition, any changes in the formulation of the product submitted for qualification testing shall be cause for re-qualification of the product. If only base oil materials have changed from the sample at qualification, the Scuffing Load Capacity (FZG) shall be determined in addition to those quality conformance tests specified in 4.4.

3.3 Material. The lubricating oil shall be a stable, homogeneous blend of virgin petroleum lubricating oil stocks plus additive agents, if necessary, to meet the requirements of this specification. However, the use of additives to improve the viscosity-temperature characteristics of the base stocks is not permitted, although additives, in quantities up to 0.5 percent by weight, may be used to meet the pour point requirement. Additives, if used, shall not contain chlorine or zinc materials. Additive components as contained in the sample tested and granted qualification approval shall not be changed without approval of the qualifying activity.

3.4 Bearing compatibility. The lubricating oil shall be noncorrosive to the bearing materials of the equipment. Acceptable results from the corrosion test (copper strip) and the bearing compatibility test as specified in table I will be considered as evidence of noncorrosiveness to bearing materials.

3.5 Oil compatibility. The lubricating oil shall be compatible with reference oils furnished by the Government. (See 4.10.)

3.6 Homogeneity. Additive agents, when used, shall remain uniformly distributed throughout the oil at all temperatures above the pour point and up to 121°C (250°F). If the oil is cooled below its pour point, it shall regain its homogeneity at temperatures of 6°C (10°F) above its pour point and shall retain that homogeneity up to 121°C (250°F). (See 4.6)

3.7 Chemical and physical. The lubricating oil shall conform to the chemical and physical requirements as specified in Table I.

3.8 Lot acceptance requirements. The results from each sample selected as specified in 4.4, when tested as specified in Table I, shall not vary from the analysis of the sample given qualification approval by more than the tolerances listed below:

Gravity, degrees API - plus or minus 1.0
 Sulfur, percent - plus or minus 20% of original value⁽¹⁾
 Viscosity
 Centistokes kinematic at 40°C (104°F) - plus or minus 8⁽²⁾
 Centistokes kinematic at 100°C (212°F) - plus or minus 1⁽²⁾
 Centistokes kinematic at 4.4°C (40°F) - maximum 870
 Pour point, °C - plus 3⁽²⁾
 Oxidation by rotating bomb - minus 15 percent maximum

- (1) For oils qualified below 0.15 percent sulfur: No minimum restriction. Plus .08 percent allowable.
- (2) Shall meet requirements of this specification (see Table I).

If base oil materials have changed from the sample at qualification, the above sulfur tolerance does not apply and the Scuffing Load Capacity (FZG) shall be determined in addition to those conformance tests specified in 4.4

3.9 Toxicity. The lubricating oil shall have no adverse effect on the health of personnel when used for its intended purpose. The lubricating oil shall be assessed by the Navy Environmental Health Center (NAVENVIRHLTHCEN) using the administrative Health Hazard Assessment (HHA). A flowchart for this process can be found as enclosure (1) of BUMEDINST 6270.8. The HHA is a review of the oil based on information submitted by the manufacturer, to assess health hazards associated with the handling, application, use and removal of the product. The lubricating oil shall not cause any environmental problems during waste disposal. (See 4.8 and 6.7).

3.10 Off-gassing. The lubricating oil shall meet the requirements in the Nuclear Powered Submarine Atmosphere Control Manual, NAVSEA Technical Manual S9510-AB-ATM-010/(U), for a usage category of Limited. (See 4.7 and 6.6).

3.11 Ozone depleting substances (ODS). The use of ODS in the composition of the lubricating oil under this specification directly or referenced in any federal test method is hereto prohibited. Environmentally safe and non-ODS alternative solvents shall be substituted in test methods for any previously specified ODS such as 1,1,1-trichloroethane, trichlorofluoroethane, perchloroethane or other chlorofluorocarbons (CFC). A dehydrated mixture of primary alcohol such as ethanol or isopropyl alcohol and non-aromatic hydrocarbon solvent resulting in a minimum flash point of 140°F plus adequate solvent action shall be used as an alternative for any ODS.

3.12 Tricresyl phosphate. If Tricresyl phosphate (TCP) is used as an antiwear additive, not more than 1.0 percent of the additive shall be the ortho isomer.

3.13 2,6-Di-tert-butylphenol (DTBP). The addition of DTBP (Chemical Abstract Service Number 128-39-2) in any lubricating oil produced under the military symbol 2190 and NATO symbol 0-250 is prohibited; this applies to both surface ships and submarine use. DTBP shall not be intentionally added to the oil. The level of DTBP, if detected, shall not exceed 10 parts per million. (See 4.9)

4. VERIFICATION

4.1 Classification of inspections. The inspection requirements specified herein are classified as follows:

- a. Qualification inspection. (see 4.2).
- b. Conformance inspection. (see 4.4).

4.2 Qualification inspection. Qualification tests shall be conducted at a laboratory satisfactory to NAVSEA. Qualification inspection shall consist of all of the tests as specified in 4.7, 4.8, 4.9 and Table I. A minimum sample size of 30 gallons is required for this testing.

TABLE I. Chemical and physical requirements and test methods.

Characteristics	Requirement	Test Method (ASTM or other)
Sulfur, %	(1)	D129, D1552, D2622, D4927, D6443, D6481
Acid Number, mg KOH/g oil, max	0.3	D974
Corrosion (in presence of salt water)	None	D665, Procedure B (2)
Corrosion test at 100°C (212°F), (Copper strip) appearance, max	1	D130
Bearing compatibility	Pass	(3)
Oil Compatibility	Pass	See 4.10
Water, percent	None	D95
Gravity, API	(1)	D287, D1298, D4052
Air release time, (mins. at 50°C, max)	20	D3427
Flash point, °C (°F), min	204 (400)	D92
Pour point, °C (°F), max	-6 (20)	D97, D5950
Viscosity:		D445
Centistokes at 4.4°C (40°F), max	870	
Centistokes at 40°C (104°F)	74-97	
Centistokes at 100°C (212°F), Min	8.0	
Emulsion test, after 30 minutes settling time Oil layer/water layer/emulsion, maximum	41/-/3	D1401(4)
Oxidation test, time required in hours to reach neutralization value of 2.0 mg KOH, min After 1000 hours:	1000	D943
Total sludge, mg maximum	100	D4310
Total iron, mg maximum	100	D4310(5)
Total copper, mg maximum	100	D4310
Oxidation by rotating bomb	(1)	D2272
Scuffing Load Capacity(FZG), Failure Load Stage	Load Stage 9	D5182
Wear test, scar diameter, mm, max	.33	D2783
Homogeneity, separation	None	See 4.6
Foam characteristics:		D892(6)(7)
After blowing/after 10 minutes		
Sequence 1, mL max	65/0	
Sequence 2, mL max	65/0	
Sequence 3, mL max	65/0	
Cleanliness, mg/100 mL max	4.0	D4898 (8)
Valve sticking characteristics	Pass	See Appendix A

Notes:

- (1) No limiting requirements. In conformance testing, values are compared to qualification results. (See 3.8).
- (2) Prior to the test, the oil shall be water -washed as follows: 300 grams of the oil to be tested shall be stirred with 50 grams of water for 30 minutes at 90 °C (194 °F) using the beaker and stirrer as specified in ASTM D665. After 30 minutes stirring, the mixture shall be transferred to a separatory funnel and left to separate; then the water layer shall be drawn off and the oil submitted to the salt-water corrosion test. The test shall be run for 24 hours.
- (3) Method used shall be FED-STD 791 Method 3452. Evidence of significant corrosion or deposit will be disqualifying. A new bearing is required for each test. The work factor portion of Method 3452 is not required.
- (4) Distilled water and stirring temperature of 54°C (130°F) shall be used. Discrete water droplets entrained in the oil layer and clinging to the wall of the cylinder may be added to the water layer volume at the rate of 0.1 mL per droplet. The results shall be reported using the format of oil layer/water layer/ emulsion layer (time in minutes). There is no requirement for water layer. The emulsion limit applies to any of the three types of emulsions defined in the test method. If more than one emulsion type is present, the 3 mL maximum limit applies to the combined volume of the different emulsion types.
- (5) Determine total iron content using the procedure and calculations described in sections 12 and 13 of ASTM D4310, except substitute iron in place of copper where appropriate.
- (6) Option A shall not be used.
- (7) A ring of bubbles around the edge of the graduate shall be considered complete collapse or 0 mL.
- (8) Test sample in accordance with ASTM D4898 using 0.8-micrometer pore diameter membrane filters.

4.3 Sampling for conformance.

4.3.1 Inspection lot.

4.3.1.1 At place of manufacture. For the purpose of sampling, one lot of lubricating oil shall consist of a manufacturer's batch. When material cannot be identified by batch, a lot shall consist of not more than 38 m³ (10,000 gallons).

4.3.1.2 At place of delivery. For the purpose of sampling, one lot of lubricating oil shall consist of all oil in a single shipment.

4.3.2 Sampling a storage tank. A representative sample of 5 gallons of lubricating oil shall be taken from each lot in accordance with ASTM D4057.

4.3.3 Sampling during loading. Samples shall be drawn at the discharge pipe where it enters the bulk carriers (tank cars, tank trucks and so forth). At least four samples shall be taken at regular intervals during the entire period of loading or filling, each sample being 1 pint. Only one sample for one continuous drum filling operation is required and shall be taken after approximately 10 percent of the volume of product has been drummed.

4.3.4 Sampling of filled containers. Where the lubricating oil is contained in drums or cans, quart samples shall be drawn from four randomly selected drums in the lot and composited, unless the lot consists of less than five containers, in which case a one gallon sample shall be drawn from one drum. The contents of each container to be sampled shall be shaken, rolled or stirred to mix the contents

thoroughly. Equal portions shall be withdrawn from approximately the center of each drum by means of a thief or other sampling device.

4.4 Conformance inspection. Each sample selected as specified in 4.3 shall be tested as specified in Table I except that the bearing compatibility, scuffing load capacity (FZG), oxidation test (ASTM D943), wear test, compatibility, homogeneity and valve sticking tests will not be required.

4.4.1 Rejection of lots. When the sample of lubricating oil fails any of the tests, this shall be cause for rejection of the lot represented by the sample.

4.5 Examination of filled containers. A random sample of filled containers shall be selected from each lot in accordance with ANSI/ASQC Z1.4 at inspection level II to verify compliance regarding fill, closure, marking, and other requirements not involving tests. Samples shall be examined for defects of the container and the closure, for evidence of leakage, and for unsatisfactory markings. Each container shall also be weighed to determine quantity. Any container in the sample having one or more defects or under required fill shall be cause for rejection of the container.

4.6 Homogeneity. After determining the pour point of the oil, return test jar and oil to cooling bath. Cool to 6°C (10°F) below the pour point and hold at that temperature for 3 hours. Remove the jar of oil from cooling bath and allow to warm to room temperature. Next, place jar and oil in oil bath, bring temperature of bath to 121 ± 2.8°C (250 ± 5°F) and hold at test temperature for 1 hour. Remove jar of oil from oil bath and allow to cool in air to room temperature. Examine test oil visually for sediment or separation of insoluble material at temperatures from 6°C (10F) above the pour point and up to 121°C (250°C). (See 3.6.)

4.7 Off-gassing. The lubricating oil shall be tested in accordance with the Nuclear Powered Submarine Atmosphere Control Manual, NAVSEA Technical Manual S9510-AB-ATM-010/(U), by a Government approved testing facility. The results shall be submitted to the Government for evaluation and approval for use. (See 3.10 and 6.6.)

4.8 Toxicity. To determine conformance to the requirements of 3.9, the lubricating oil shall be evaluated using the HHA process. Sufficient data to permit a HHA of the product shall be provided by the manufacturer/distributor to the NAVENVIRHLTHCEN. To obtain current technical information requirements specified by the NAVENVIRHLTHCEN, see 6.7.

4.9 2,6-Di-tert-butylphenol (DTBP). Analytical data from a NAVSEA-approved laboratory shall be submitted to document relative absence of DTBP, and, if detected, shall not exceed 10 ppm. (See 3.13.)

4.10 Oil compatibility. Oil shall be considered compatible with the referenced oils furnished by the Government if 1:1 mixtures of a test oil with all reference oils give passing values on the oxidation (ASTM D943), corrosion (salt water), foam and emulsion tests. (See 3.5.)

5. PACKAGING

5.1 Packaging. For acquisition purposes, the packaging requirements shall be as specified in the contract or order. (See 6.2.) When actual packaging of materiel is to be performed by DoD personnel, these personnel need to contact the responsible packaging activity to ascertain requisite packaging requirements. Packaging requirements are maintained by the Inventory Control Point's packaging activity within the Military Department or Defense Agency, or within the Military Department's System

Command. Packaging data retrieval is available from the managing Military Department or Defense Agency's automated packaging files, CD-ROM products or by contacting the responsible packaging activity.

6. NOTES

(This section contains information of a general or explanatory nature that may be helpful, but is not mandatory.)

6.1 Intended use. The lubricant is intended for use in main and auxiliary turbines and gears, air compressors and certain hydraulic equipment, as well as for general mechanical lubrication.

6.2 Acquisition requirements. Acquisition documents must specify the following:

- a. Title, number and date of this specification.
- b. Issue of DoDISS to be cited in the solicitation, and if required, the specific issue of individual documents referenced (See 2.2.1).
- c. Quantity.
- d. Packaging required (See 5.1).

6.3 Qualification. With respect to products requiring qualification, awards will be made only for products which are, at the time of contract award, qualified for inclusion in Qualified Products List QPL-17331 whether or not such products have actually been so listed by that date. The attention of the contractors is called to these requirements, and manufacturers are urged to arrange to have the products that they propose to offer to the Federal Government tested for qualification in order that they may be eligible to be awarded contracts or purchase orders for the products covered by this specification. Information pertaining to qualification of products may be obtained from Commander, Naval Sea Systems Command, ATTN: SEA 05Q, 1333 Isaac Hull Ave., SE, Stop 5160, Washington Navy Yard DC 20376-5160.

6.4 Material safety data sheets (MSDS). Contracting officers will identify those activities requiring copies of completed MSDS prepared in accordance with FED-STD-313. In order to obtain the MSDS, FAR clause 52.223-3 must be in the contract.

6.5 International interest. Certain provisions of this specification are the subject of international standardization agreement NATO-STANAG-1135. When amendment, revision or cancellation of this specification is proposed which will modify the international agreement concerned, the preparing activity will take appropriate reconciliation action through international standardization channels including departmental standardization offices to change the agreement or make other appropriate accommodations.

6.6 Off-gassing. Materials to be installed in submarines are to be controlled to prevent off-gassing, which contaminates the atmosphere and results in health hazards to personnel or deleterious effects on machinery. These controls are accomplished through the Submarine Material Control Program, which is described in the Nuclear Powered Submarine Atmosphere Control Manual, NAVSEA Technical Manual S9510-AB-ATM-010/(U). Under the Submarine Material Control Program, all materials considered for use on submarines require certification and assignment of a usage category. Under the certification process, candidate materials are selected by Navy activities or contractors, and a request for certification is submitted to Commander, Naval Sea Systems Command, ATTN: SEA 05Z9, 1333 Isaac

Hull Ave., SE, Stop 5122, Washington Navy Yard DC 20376-5122. The certification request is accompanied by detailed information, including descriptions of the material. A chemical analysis is conducted, which is normally accomplished through off-gas testing. The off-gas test is required to be conducted in a Government approved laboratory designated by the preparing activity. Information pertaining to this test requirement may be obtained from Commander, Naval Sea Systems Command, ATTN: SEA 05Z9, 1333 Isaac Hull Ave., SE, Stop 5160, Washington Navy Yard DC 20376-5160. Based on the chemical analysis results, a usage category is assigned to the material defining whether, and to what extent, the material may be used on submarines.

6.7 Toxicity evaluation. The NAVENVIRHLTHCEN requires sufficient information to permit a HHA of the product. Any questions concerning toxicity and requests for HHA should be addressed to the Commanding Officer, Navy Environmental Health Center, Attn: Hazardous Materials Department, Industrial Hygiene Directorate, 620 John Paul Jones Circle, Suite 1100, Portsmouth, VA 20378-2103. Upon receipt of the HHA, a copy should be provided to Commander, Naval Sea Systems Command, ATTN: SEA 05M3, 1333 Isaac Hull Ave., SE, Stop 5133, Washington Navy Yard DC 20376-5133.

6.8 Subject term (Key word) listing

2190 tep
Air compressors
Bearings
Gas turbine auxiliaries
Line shaft bearings

6.9 Changes from previous issue. Marginal annotations are not used in this revision to identify changes with respect to the previous issue due to the extent of the changes.

APPENDIX A

VALVE-STICKING CHARACTERISTICS

A.1 SCOPE

A.1.1 Scope. This appendix outlines a procedure to determine the valve-sticking tendency of candidate oils when used with shipboard hydraulic control valves. This appendix is a mandatory part of the specification. The information contained herein is intended for compliance.

A.1.2 Summary. The procedure consists of measuring the actuation force required to shift the spool of shipboard hydraulic control valves after 24 hours of static contact with candidate fluid, when tested as specified herein.

A.2 APPLICABLE DOCUMENTS

A.2.1 Government documents.

A.2.1.1 Specifications. The following specifications, standards, and handbooks form a part of this document to the extent specified herein. Unless otherwise specified, the issues of these documents are those listed in the issue of the Department of Defense Index of Specifications and Standards (DoDISS) and supplement thereto, cited in the solicitation (see 6.2).

SPECIFICATION

MILITARY

MIL-PRF-680 - Degreasing Solvent

(Unless otherwise indicated, copies of the above specifications, standards, and handbooks are available from the Standardization Document Order Desk, 700 Robbins Avenue, Building 4/D, Philadelphia, PA 19111-5094 or <http://astimage.daps.dla.mil/quicksearch/> or www.dodssp.daps.mil.)

A.3 EQUIPMENT

A.3.1 Apparatus. The test apparatus is shown schematically on figure 1. It consists of the following:

- a. Two 20-L (5-gallon) sumps, high density polyethylene with spigot at the bottom.
- b. Air operated piston pump capable of 1 liter/minute (L/min) capacity at 20.7 megapascals (MPa) (3000 pounds per square inch (lb/in²)).
- c. Two accumulators, bladder type, 4L (1 gallon) capacity each with a nitrogen precharge of 10 MPa (1500 lb/in²).
- d. Flow control valves, eight, each 20.7 MPa (3000 lb/in²) rating.
- e. Test valves, one each Bendix models 3191350-1 and 3188561-4.
- f. Pressure control switch capable of maintaining 20.7 ± 1.7 MPa (3000 ± 250 lb/in²).
- g. Pressure gauge, 0-34.5 MPa (0-5000 lb/in²).
- h. Enclosure capable of maintaining $38 \pm 1^\circ\text{C}$ ($100 \pm 1.8^\circ\text{F}$).
- i. Waste oil container.

A.3.2 Materials. The materials shall consist of the following:

- a. Test oil, 20 L (5 gallons), meeting cleanliness requirement as specified in table I.
- b. Solvents: MIL-PRF-680, Type III.

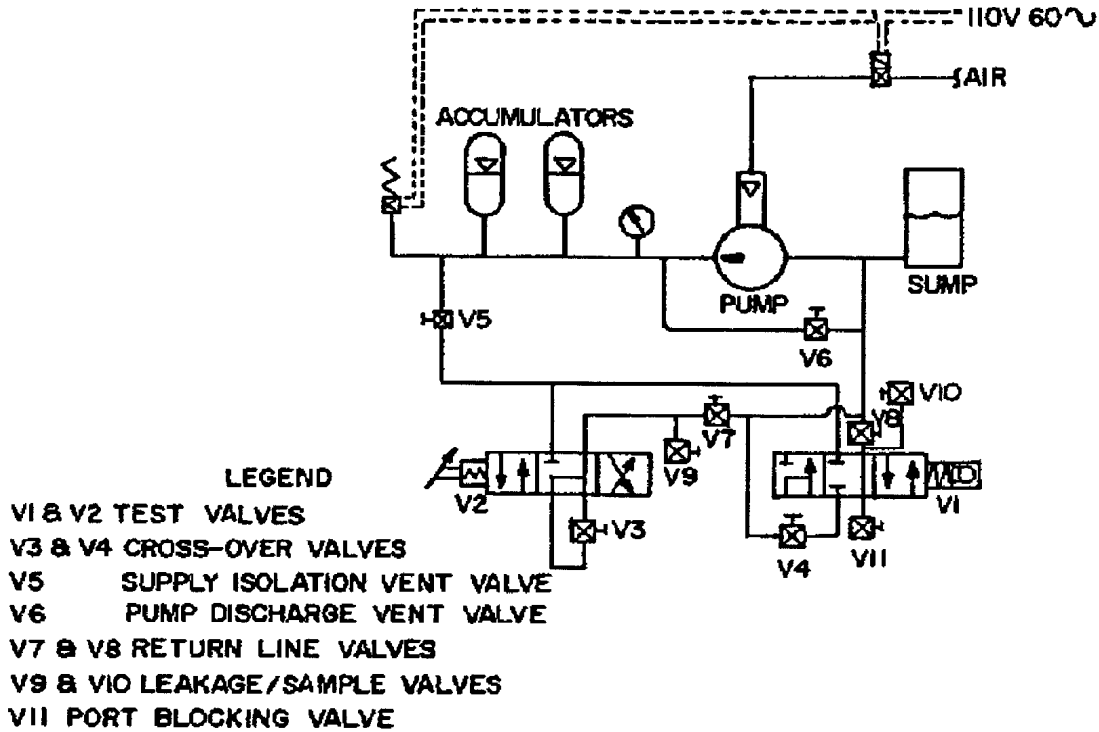

SH 11338

FIGURE 1. Hydraulic valve test loop.

A.4 TEST PROCEDURE.

A.4.1 Test valve cleaning. The test valves shall be cleaned by flushing with solvent as described in A.4.2. If the actuation force increases when testing with the reference test fluid compared with previous runs, the valves shall be disassembled and cleaned. The pipe loop shall be dismantled at all take-down joints and the fluid allowed to drain. The valves shall be disassembled, and the spool, packings, o-rings and sleeve assemblies examined. After removal of the o-rings and packings, the valve bodies, spools, sleeve assemblies and other dismantled parts shall be cleaned under a laboratory fume hood by rinsing first with hexane(s), heptane, or naphtha and then with isopropyl alcohol. Solvents shall be particularly free and dry. Should any evidence of deposits still remain, the parts shall be cleaned further by wiping with a soft, lint-free cloth, wet with isopropyl alcohol. Discard any o-rings or packings which appear damaged. Place o-rings or packings back on parts after they have dried.

A.4.2 Sump cleaning. The sump is drained of oil and rinsed four times with MIL-PRF-680, Type III and air dried.

A.4.3 System cleaning. With valves V1 and V2 removed from their base plates and other valves open, MIL-PRF-680, Type III solvent shall be pumped through the system lines until there is no evidence of previous test oil being present. Add test oil to the sump and pump the test oil through the system lines to valves V1 and V2.

A.4.4 System flushing. Connect the pump suction to the MIL-PRF-680, Type III solvent sump and flush the system with solvent according to the following procedure:

- a. Flush the pump: Close the supply valve V5. Open the bypass valve V6 to the waste oil container. Start the pump and flush until new fluid is being discharged. Secure the pump.
- b. Flush the accumulators: Close V5 and V6. Start the pump and charge the accumulators to 15 MPa (2000 lb/in²). Secure the pump. Open V6 to discharge the accumulators to the waste oil container. Charge and discharge the accumulators a second time. Close V6.
- c. Flush the lines and valve manifolds. Open V5 and start the pump. Flush until new fluid is discharged from both manifolds. Secure the pump.
- d. Flush the test valves: Install V1 and V2. Close V6. Open V3, V4, V5, V7 and V8. Open V1 (See NOTE 1). Center V2. Start the pump. Adjust system pressure to 3.4 MPa (500 lb/in²) using V4. Cycle test valve V1 10 times (See NOTE 2). Center V1. Open V2 (See NOTE 3). Adjust system pressure to 3.4 MPa (500 lb/in²) using V3. Cycle test valve V2 ten times (See NOTE 2).

NOTE 1. V1 is open when it is shifted to one of its extreme positions. This is the same direction the valve is pulled while making the valve actuating force measurements.

NOTE 2. A valve cycle consists of starting at the center position, moving the spool to one extreme position, reversing to the other extreme position and returning to center.

NOTE 3. V2 is open when in either extreme position.

- e. Center test valves V1 and V2. Close V3 and V4. Charge the accumulators to 20.7 MPa (3000 lb/in²). Secure the pump. Cycle test valve V1, dropping system pressure 1.4 MPa (200 lb/in²) per cycle, until the accumulators are discharged. Valve V4 is used to control the rate of pressure drop. Recharge accumulators and repeat for test valve V2, using V3 to control the rate of pressure drop. Open valve V6.
- f. Connect the pump suction to the test oil sump and repeat the flushing procedure with test oil.

A.4.5 Test operation.

A.4.5.1 After flushing the system with test oil, measure each test valve actuation force at 0 MPa (0 lb/in²) and return the valve spool to the center position. Repeat for each test valve until three consecutive measurements are within a 2.2 N (0.5 lbf) range, which does not exceed 45 N (10 lbf).

A.4.5.2 Center test valves V1 and V2, close valves V3, V4, V7 and V8, and open valves V9 and V10. Start pump and charge accumulators to 20.7 MPa (3000 lb/in²).

A.4.5.3 Repeat the procedure specified in A.4.5.1 and measure each test valve actuation force. Complete the valve cycle to return the spools to the center positions.

A.4.5.4 Center the test valve spools. Bring the system to a temperature of $38 \pm 1^\circ\text{C}$ ($100 \pm 1.8^\circ\text{F}$). Allow valves to remain at these conditions undisturbed for 24 hours. Measure valve fluid leakage rates during the first 2 hours and at end of the 24-hour period.

A.4.5.5 After the 24-hour period, measure actuation force for each test valve. Complete the valve cycle to return the spool to the center positions.

A.4.5.6 Close valves V9 and V10. Open valves V7 and V8. Secure the pump. Using valve V4 to control rate of pressure drop through V1, and V3 to control rate of pressure drop through V2, reduce system pressure to 0 MPa (0 lb/in²) by alternately cycling each test valve (V1 and V2) three times, allowing a 2.8 MPa (400 lb/in²) pressure drop for each cycle. Open valve V6.

A.5 RATING

A.5.1 Rating. A passing rating is given to a candidate oil when the initial actuation force after the 24-hour aging for each test valve (See A.4.5.5) averages 20 lbf (89 N) or less with no individual initial actuation force exceeding 25 lbf (111 N).

Preparing activity:
Navy - SH
(Project 9150-1246)